

# Double Limit Switch LS-24



- Galvanically isolated input/output and supply.
- Programmable input and relay functions.
- Potentiometers for operational level and setting of hysteresis
- LED in the front indicate active relay.
- Supply voltage 24, 115, 230 VAC, 24 VDC
- Standard 11-pole relay socket

## Applications:

Larm detectors or 2-point regulators together with other measuring test converters.

Min/max-control unit for instance for pumping out together with a level indicator..

## Technical characteristics:

Input current:	0/4-20 mA
Input resistance:	30 ohm
Input voltage:	0/2-10 V
Input resistance:	Approx. 10 Mohms
Relay output:	2 free change-over contacts.
Relay function:	High- or low level alarms.
Limit value adjustment:	12 mm knob, 250° scale.
Hysteresis:	1-25% adjustable on 25-turns trim potentiometer.
Alarm indication:	3 mm yellow LED in front.
Auto holding relay 1: (Programmable)	Relay 1 operates at set high level and releases when relay 2 activates at set low level.
Measuring circuit monitoring: (Programmable)	When the relay is activated for low level alarm it will release when the input signal drops below approx. 4 mA.



## Elektrical specifications:

Voltage supply AC:	24, 115, 230 V $\pm$ 10 %, 50-60 Hz, Approx. 4 VA
Voltage supply DC:	24 VDC $\pm$ 15 %, 80 mA (Both relays active)
Scale correspondence:	Better than 5 %
Repeating accuracy:	Better than 0,5 %
Hysteresis:	Adjustable 1-25% standard
Voltage output:	15 VDC $\pm$ 5 %, max 20 mA
Relay contacts:	1000 VA (resistive load), 250 VAC, 4 A
EMC-data:	EN50 081, emission, EN50 082, immunity
Ambient temperature:	-20 to +50 °C



Bangatan 15  
S-273 34 Tomelilla  
Sweden  
www.anatronic.se

Phone +46 417 144 11  
Fax +46 417 142 55  
info@anatronic.se

## Order: LS-24 - Input signal - Output signal - Supply

Input signal:	Relay functions:	Supply:
0-20 mA -020	High 1, High 2 -HH	24 VDC -724
4-20 mA -420	High 1, Low 2 -HL	24 VAC -024
0-10 VDC -010	Low 1, High 2 -LH	115 VAC -115
2-10 VDC -210	Low 1, Low 2 -LL	230 VAC -230
	Hold 1-2 act. -HXL	
	Failsafe 1 -LF1	
	Failsafe 2 -LF2	

### Block diagram:

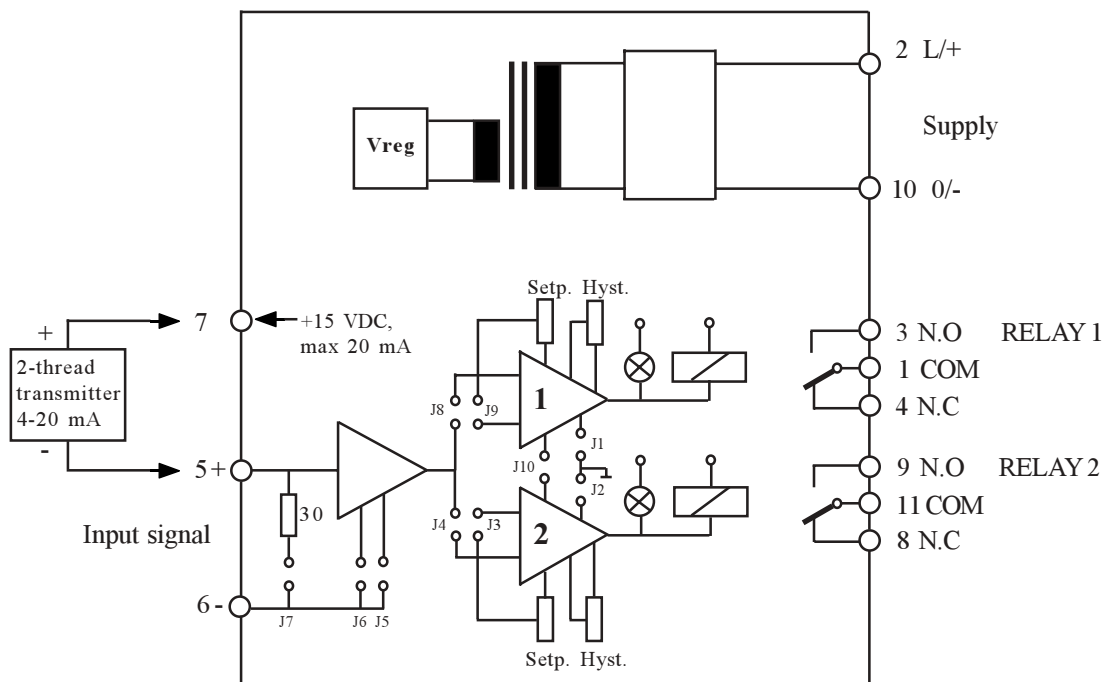

### Programming jumpers:

Input signal	Jumpers	Function	Relay 1	Relay 2
0-20 mA	J5, J6, J7		J1 J8 J9 J10 J2 J3 J4	
4-20 mA	J6, J7	High alarm	○ — ○ ○ ○ ○	○ — ○ ○ ○ ○
0-10 VDC	J5	Low alarm	○ — ○ ○ ○ ○	○ — ○ ○ ○ ○
2-10 VDC	-	Hold	○ — ○ ○ ○ ○	○ — ○ ○ ○ ○
		Failsafe	○ — ○ ○ ○ ○	○ — ○ ○ ○ ○

### Mechanical Specifications:

